

ESO

Emulsion and oil separator

ESO is designed for separating oil from contaminated coolant in machine tools. It features two outlets: one for discharging the separated oil and the other for returning oil-free coolant back to the machine tank. A level indicator allows monitoring of the separation process by visually displaying the distinct layers of the contaminated liquid. Magnetic attachment allows easy attachment to machine tanks.

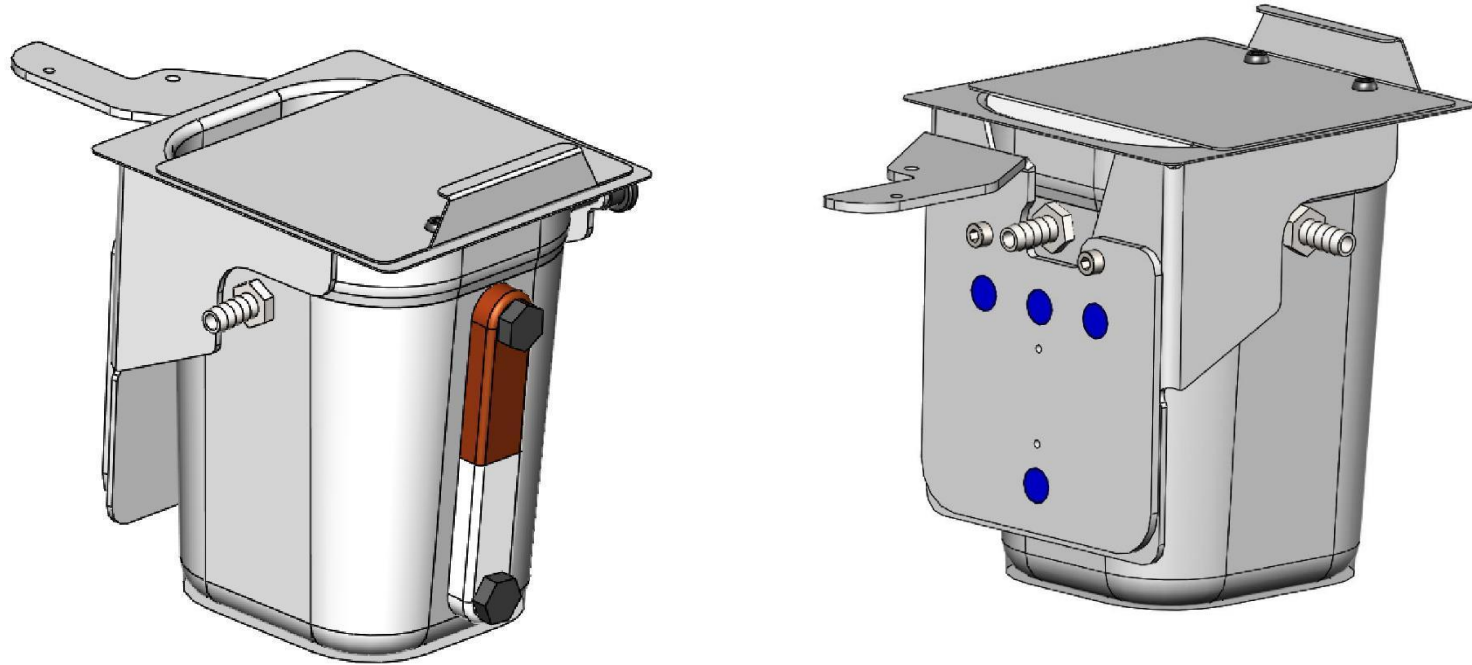

Benefits of ESO

- Extends fluid life
- Returns clean emulsion to the machine tool tank
- Reduces the costs of disposal of polluted liquid
- Removable, easy handling
- Easy cleaning method
- Level and separation indicator
- Can be installed with the MINIMAX, BOS and BOS E separator

Installation options

BOS-ESO

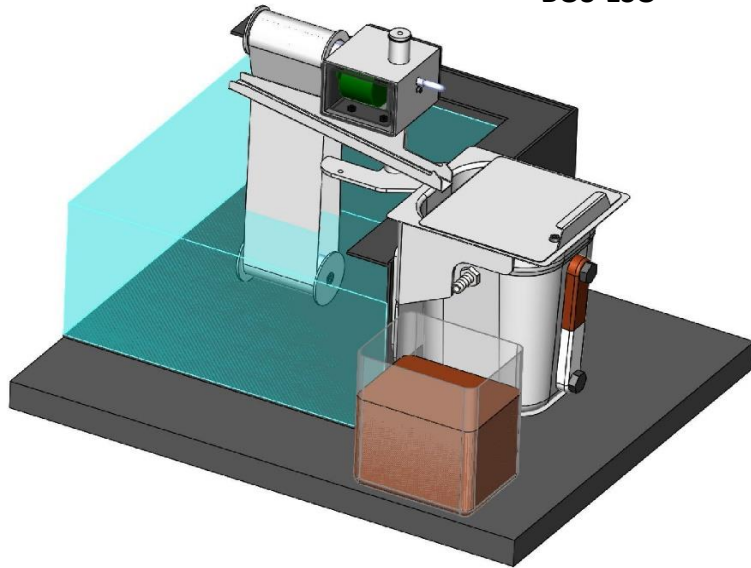

MiniMax-ESO

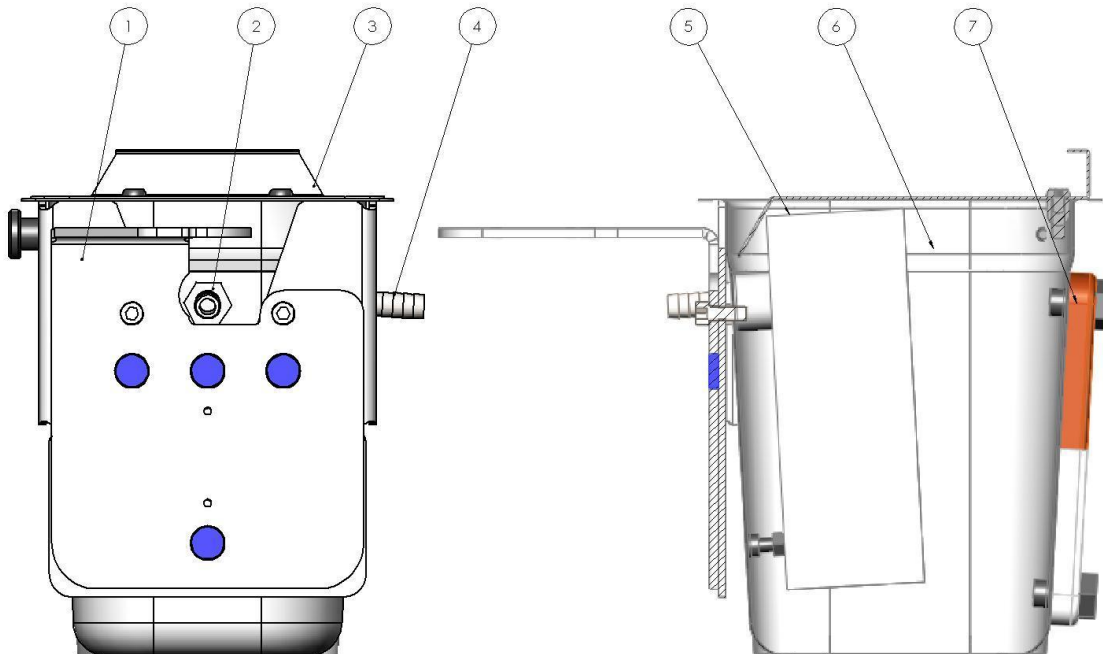
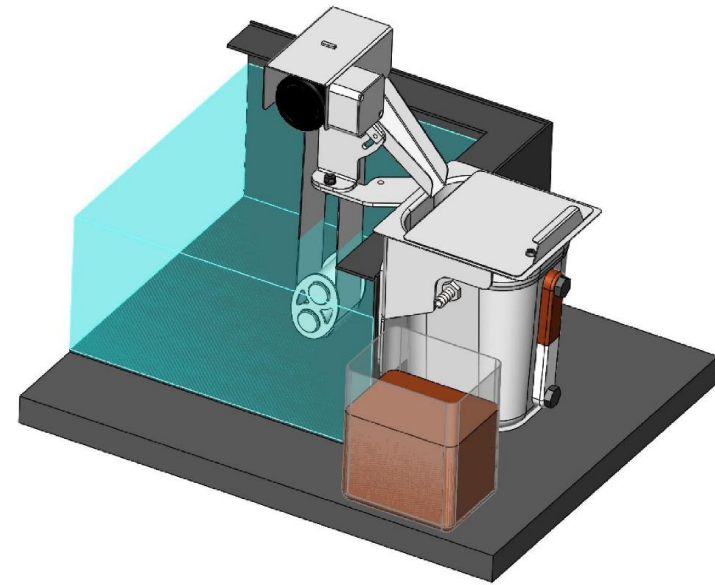

Description of device parts

- 1- Magnetic holder
- 2- Emulsion drain valve
- 3- Lid
- 4- Oil drain valve
- 5- Separation wall
- 6- INOX separation container
- 7- Level indicator